

SPECIFICATIONS	
CONTACT CARRIER MATERIAL	TPU
MOLDED MATERIAL/COLOR	TPU/BLUE-GRAY
CONTACT MATERIAL/PLATING	BRASS/GOLD
COUPLING NUT MATERIAL/PLATING	BRASS/NICKEL
HOUSING MATERIAL/PLATING	BRASS/NICKEL
RATED CURRENT [A]	7.0 A
RATED VOLTAGE [V]	300 V
OUTER JACKET MATERIAL/COLOR	PVC/GRAY
CONDUCTOR INSULATION MATERIAL	PE (DATA), PVC (POWER)
NUMBER OF CONDUCTORS [AWG]	2x16 AWG, 2x20 AWG, 20 AWG DRAIN
SHIELDING	FOIL (PAIRS), FOIL (OVERALL)
TEMPERATURE RATING	-40°C to +80°C (-40°F to +176°F)
PROTECTION CLASS	NEMA 1,3,4,6P,12 & IECIP67, IP68,IP69,IP69K
MAX. PANEL THICKNESS	.050" (1.3mm) to .250" (6.4mm)

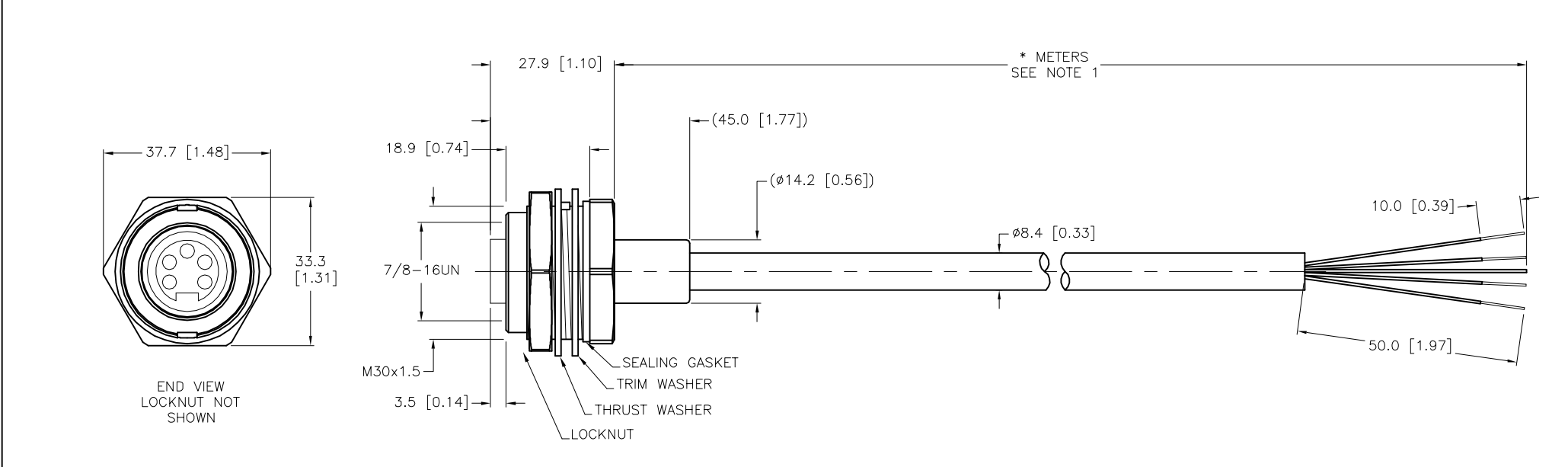

CABLE LENGTH	TOLERANCE*
ALL LENGTHS	+ 4% (OR 50mm) OF LENGTH - 0% (OR 0mm) OF LENGTH WHICHEVER IS GREATER
STRIP LENGTH	TOLERANCE*
0-7mm	±0.5mm
8-29mm	±1.0mm
30-49mm	±2.0mm
50-69mm	±3.0mm
70-100mm	±4.0mm
OVER 100mm	±5.0mm

\* UNLESS OTHERWISE SPECIFIED

NOTES:  
 1. "\*" INDICATES CABLE LENGTH IN METERS. CONTACT TURCK TO ORDER SPECIFIC LENGTHS.

SOURCE DRAWING - FOR REFERENCE ONLY

RELATED DOCUMENTS 1. 2. 3. 4.	3RD ANGLE PROJECTION	THIS DRAWING IS CONFIDENTIAL AND THE PROPERTY OF TURCK INC. USE OF THIS DOCUMENT WITHOUT WRITTEN PERMISSION IS PROHIBITED.	3000 CAMPUS DRIVE MINNEAPOLIS, MN 55441 1-800-544-7769 (763) 553-7300 (763) 553-0708 fax www.turck.us	
	MATERIAL		DRFT RDS APVD	DATE 08/30/02 SCALE 1=1.3
FINISH	ALL DIMENSIONS DISPLAYED ON THIS DRAWING ARE FOR REFERENCE ONLY	UNIT OF MEASUREMENT <b>MILLIMETER [ INCH ]</b>	IDENTIFICATION NO.	REV H
H UPDATE PROTECTION CLASS	CBM 04/13/21 76628	CONTACT TURCK FOR MORE INFORMATION	DO NOT SCALE THIS DRAWING	FILE: 777005128
REV DESCRIPTION	BY DATE ECO NO.			SHEET 1 OF 1